

Project	Quantity	Item #
Model Specified:		CSI Section 11400

Compact Sandwich Prep Tables with Drawers/Self-Contained R290



Model USD2709DO-0300



Stainless Exterior,
Anodized Aluminum
Interior

27", 32", 60" & 72" Wide Models

27" Wide Two Drawer Model	USD2706DO-0300
27" Wide Two Drawer Model	USD2709DO-0300
32" Wide Two Drawer Model	USD3208DO-0300
32" Wide Two Drawer Model	USD3212DO-0300
60" Wide Four Drawer Model	USD6012DD-0300
60" Wide Four Drawer Model	USD6024DD-0300
72" Wide Four Drawer Model	USD7212DD-0300
72" Wide Four Drawer Model	USD7218DD-0300
72" Wide Four Drawer Model	USD7224DD-0300
72" Wide Four Drawer Model	USD7230DD-0300

Traulsen shares your commitment to Corporate Sustainability initiatives and knows that it is more than just meeting the current and future regulatory requirements set by the EPA and DOE. We are committed to reducing global warming potential (GWP) and saving energy consumption while maintaining the performance and quality you have come to expect from Traulsen products.

Traulsen is proud to offer the North American market a broad selection of self-contained reach in and compact undercounter refrigeration with R290, a natural recurring refrigerant with a GWP of (3), the lowest currently available in our industry

Standard Product Features

- High Quality Stainless Steel Exterior Top, Sides & Drawer(s)
- Durable, Corrosion Resistant Anodized Aluminum Interior
- Provides NSF Standard 7 Performance, Even When Using 6" Deep Top Pans - A Traulsen Exclusive
- Front Breathing Self-Contained Refrigeration System
- Standard Work Height 36-1/4" (see "optional accessory kits for lower height casters to meet ADA requirements or provide lower work heights).
- Environmentally Friendly R290 Refrigerant
- Top Cut-Outs Accommodate Sixth Size Pans (divider bars and 4" deep plastic sixth size pans provided)
- Reinforced Top Pan Ledge (holds pans securely level, year after year)
- Stainless Steel Insulated Top Pan Lid with Two Open Positions
- Reversible, Full Length White Nylon Cutting Board
- Automatic Non-Electric Condensate Evaporator
- Full-Length Drawer Handle with Gasket Guard
- Magnetic Snap-In Drawer Gasket(s)
- Self-Closing Drawers with Stay Open Feature
- 16-Gauge Stainless Steel Drawer with Slide
- Interior Mounted Thermometer
- 8' Cord & Plug Attached
- Set of Four (4) 4" Casters (6 for 60" & 72" models)
- Three Year Parts And Labor Warranty
- Five Year Compressor Warranty



Sustainability Features

- SNAP compliant R290 (GWP 3) Refrigerant EPA Rule 20
- All Metal Construction And Long Equipment Life Reduces Pressure On Landfills
- Real World Energy Efficiency Helps Reduce Fossil Fuel Emissions

Optional Accessory Kits*

- **CK20** (four 6" high casters for 27" & 32" models)
- **CK21** (six 6" high casters for 60" & 72" models)
- **CK24** (four 3-1/2" high casters for 27" & 32" models)
- **CK25** (six 3-1/2" high casters for 60" & 72" models)
- **CK28** (four 2-1/2" high casters for 27", 32" & 48" models)
- **CK27** (six 2-1/2" high casters for 60" & 72" models)

*All optional accessory kits are shipped separately for field installation.

Factory Installed Options

- Stainless Steel Finished Back



This unit is listed to UL 471, CSA 120 and NSF 7 by an approved NRTL. Consult the factory or unit data plate for approval information.

Approval: _____



TRAULSEN
4401 BLUE MOUND RD.
PHONE 1 (800) 825-8220
Website: www.traulsen.com

FT. WORTH, TX 76106
FAX-MKTG. 1 (817) 624-4302

Project	Quantity	Item #
Model Specified:		CSI Section 11400

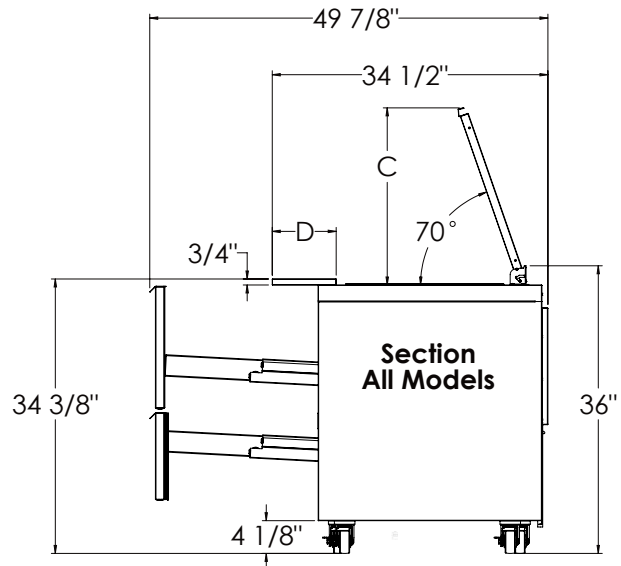
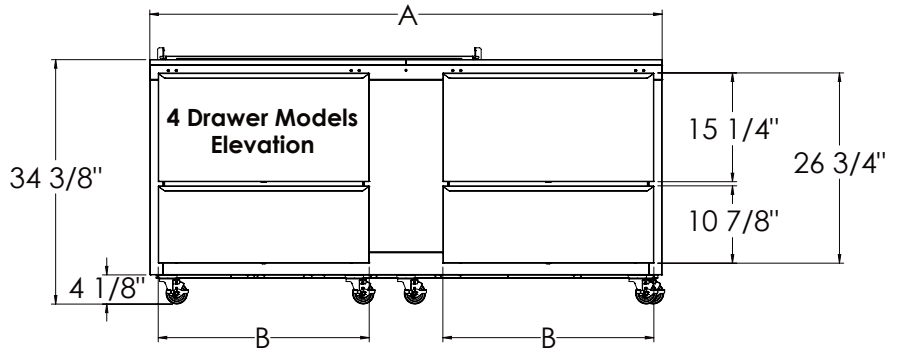
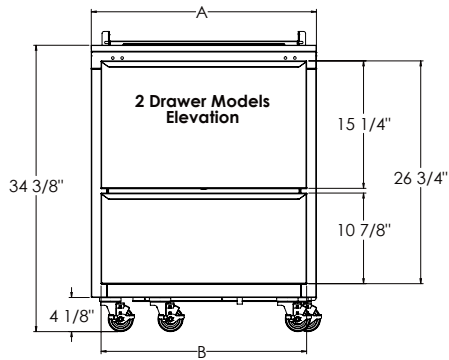

Cabinet Dimensional Data							
Model	# of 1/6 Size Pans Top	# of 1/6 Size Pans Per Drawer	# Of Drawers Per Cabinet	A Width - Cabinet	B Width - Drawer	C Height-lid Open at 70 Degrees	D Depth-Cutting Board
USD2706DO-0300	6	6	2	27"	24 5/8"	16 1/4"	12"
USD2709DO-0300	9	6	2	27"	24 5/8"	22 3/16"	8"
USD3208DO-0300	8	8	2	32"	29 5/8"	17 1/2"	12"
USD3212DO-0300	12	8	2	32"	29 5/8"	23 5/8"	8"
USD6012DD-0300	12	9 top & 6 bottom	4	60"	24 5/8"	16 1/4"	12"
USD6024DD-0300	24	9 top & 6 bottom	4	60"	24 5/8"	23 3/4"	8"
USD7212DD-0300	12	8	4	72"	29 5/8"	16 1/4"	12"
USD7218DD-0300	18	8	4	72"	29 5/8"	23 3/4"	8"
USD7224DD-0300	24	8	4	72"	29 5/8"	23 3/4"	8"
USD7230DD-0300	30	8	4	72"	29 5/8"	23 3/4"	8"

Project

Quantity

Item #

Model Specified:

CSI Section 11400

Top Pan Configuration

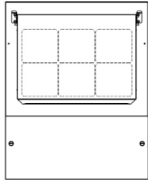

USD2706DO-0300

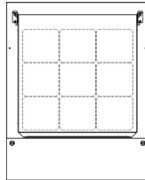

USD2709DO-0300

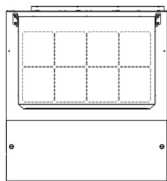

USD3208DO-0300

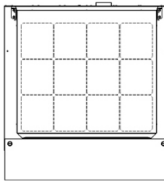

USD3212DO-0300

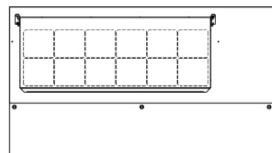
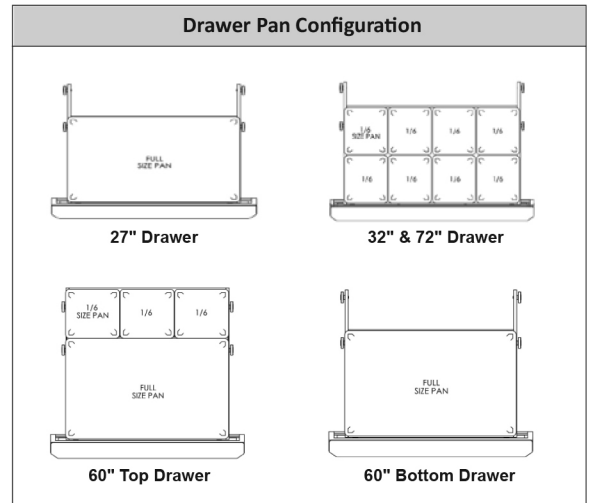

USD6012DD-0300

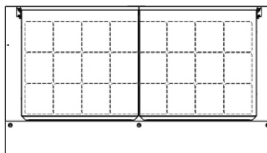

USD6024DD-0300

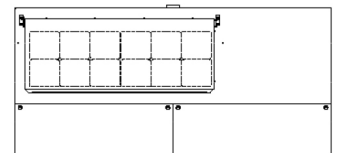

USD7212DD-0300

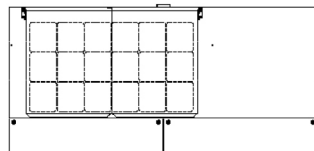

USD7218DD-0300

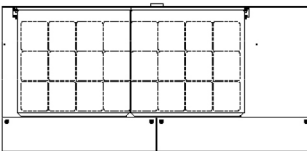

USD7224DD-0300

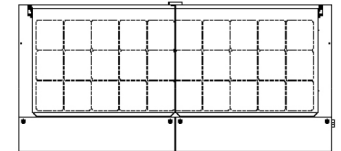

USD7230DD-0300



TRAULSEN
4401 BLUE MOUND RD.
PHONE 1 (800) 825-8220
Website: www.traulsen.com

FT. WORTH, TX 76106
FAX-MKTG. 1 (817) 624-4302

Project	Quantity	Item #
Model Specified:		CSI Section 11400

Specifications

Construction, Hardware and Insulation

Cabinet exterior front, one piece sides, pan lid, and drawers are constructed of 22 gauge stainless steel. Cabinet interior is constructed of anodized aluminum. The exterior cabinet back and bottom are constructed of galvanized steel.

The cabinet is insulated with an average of 2" thick high density, non-CFC, foamed in place polyurethane.

A 3/4" thick, full-length, reversible white nylon cutting board is supplied standard.

Top Pans & Cover

Each model is supplied standard with its full compliment of 4" deep plastic 1/6 size pans and stainless steel pan dividers. The insulated lift-up pan cover is constructed of stainless steel, and is easily removable for cleaning.

Refrigeration System-R290

A balanced, rear mounted, front breathing, self-contained refrigeration system using R290 refrigerant is provided. It features a capillary tube metering device, air-cooled hermetic compressor, a forced air evaporator coil and a non-electric condensate evaporator. An 8' cord and plug is provided. Standard operating temperature of the refrigerated base is 34 to 38°F.

Drawers

They are constructed using 16 gauge stainless steel drawer slides and 1-5/16" diameter stainless steel rollers. Gasket profile and Santoprene® material simplify cleaning and increase overall gasket life. Drawers include both a self-closing and stay-open feature.

Warranties

Both a three year parts and labor warranty and a five year compressor warranty (self-contained models only) are provided standard.

Electrical & Refrigeration Data			Shipping Data		
115/60/1 R290 NEMA 5-15P			(42"D x 41"H)		
Model	Full Load Amps	BTU/HR - HP	Width - crated	Volume - crated cu. ft.	Weight - lbs.
USD2706DO-0300	7.2	1525 (1/4)	45"	45	386 net/425 gross
USD2709DO-0300	7.2	1525 (1/4)	45"	45	386 net/425 gross
USD3208DO-0300	7.2	1525 (1/4)	45"	45	255 net/300 gross
USD3212DO-0300	7.2	1525 (1/4)	45"	45	255 net/300 gross
USD6012DD-0300	7.2	1525 (1/4)	69"	69	457 net/500 gross
USD6024DD-0300	7.2	1525 (1/4)	69"	69	457 net/500 gross
USD7212DD-0300	7.2	1525 (1/4)	84"	84	560 net/600 gross
USD7218DD-0300	7.2	1525 (1/4)	84"	84	560 net/600 gross
USD7224DD-0300	7.2	1525 (1/4)	84"	84	560 net/600 gross
USD7230DD-0300	7.2	1525 (1/4)	84"	84	560 net/600 gross

NOTES:

- Overall depth figure includes standard cutting board.
- Height shown when mounted on 4" casters.
- Based on a 90 degree F ambient and 20 degree F evaporator.
- This unit may be manufactured in other electrical characteristics and may have additional regulatory agency approvals. Consult factory for other electrical characteristics and agency approvals based on specific electrical and country requirements. (For exact electrical information and approval marks, always refer to the data label of the unit.)
- Continued product development may necessitate specification changes without notice.

Part No. TR35975 (REV. 09-15-16)

TRAULSEN
4401 BLUE MOUND RD.
PHONE 1 (800) 825-8220
Website: www.traulsen.com

FT. WORTH, TX 76106
FAX-MKTG. 1 (817) 624-4302

