

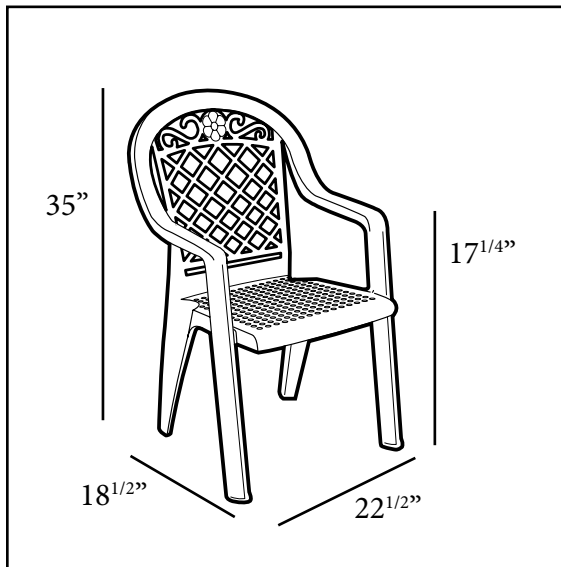

Savannah Highback Stacking Armchair

Passes ASTM F 1561-96 Class B performance standard for commercial outdoor seating



Features & Benefits **Warranty: 3 Yrs.**

- Specifically built for food service use.
- Open lattice back design to provide cool, yet positive support.
- Made of Kevring® cast synthetic resin, a proprietary resin composite specifically developed to allow the replication of cast metal without the maintenance and at a fraction of the cost.
- True metal texture and a satin finish.
- Will stay cool in the sun.
- Will retain its original color, texture, and finish with little maintenance and without rusting.
- Rated to 300 pounds for safe use in commercial environments.
- Stacks for easy storage.

Product Specifications						
Product Description	Reference Number	Color	UPC Code 014306	Weight Each (lbs.)	Master Pack	Master Pack Volume (cu. ft.)
Savannah Highback Stacking Armchair	US103137	Bronze Mist	131405	8.32	20	37.42
	US413137	Bronze Mist	131405	9.30	4	13.98
	US103102	Charcoal	131399	8.32	20	37.42
	US413102	Charcoal	131399	9.30	4	13.98
	US103185	Metal Green	131436	8.32	20	37.42
	US413185	Metal Green	131436	9.30	4	13.98