

1624 Lincoln Aperion®

Impinger Conveyor Oven

Models

- 1624 Electric
- 1624 Electric Ventless
- 1624 Gas



Shown with optional half pass window.

Benefits

Faster Bake Times

- High output elements and burners combined with dual blower motors reduce cook times by 30% vs. traditional impingement conveyors

Better Bake Results

- Independent top and bottom adjustable air control allows you to optimize bake results
- Balanced air flow from front to back and side to side translates to consistently, uniform bake appearance

Easy Operation

- Front located, easyTouch controls with 20 recipe pre-sets
- Easy one-touch belt direction change
- One-touch ECO mode holds oven at set-point temperature while minimizing energy use during slow time periods
- Optional half pass window door is ideal for slices or other items requiring less cook time

Easy Cleaning

- Front removable door for easy access to finger assemblies
- Front removable universal finger assemblies are easy to clean
- Stainless exterior and interior components are easy to clean

Specifications

General

- Stainless steel design
- Audible noise targeted at <70 dB Front-of-House (FOH) application
- Front removable door and finger assemblies
- All models triple stackable in ventless and non-ventless operation

Options

- Electric ovens available with triple catalysts for VENTLESS operation
- Optional front-loading half pass glass door with cool touch handle
- 6" or 12" entry and exit shelves
- Countertop legs included, floor standing legs with casters optional
- Single and three phase cord sets with plug

Cooking

- 20 second to 30 minute cook time
- 20 recipe pre-sets for easy operation
- Independent, adjustable top and bottom air flow control
- Vented Models:
 - Temperature range 250°F - 600°F [121°C - 316°C]
 - 100% top and bottom fan speed
- Ventless Models:
 - Temperature range 250°F - 550°F [121°C - 288°C]
 - Maximum 70% top and 100% bottom fan speed

Conveyor

- Conveyor is 16" wide x 48" long
- Front removable
- Includes end stop



1624 Lincoln Aperion® Impinger Conveyor Oven

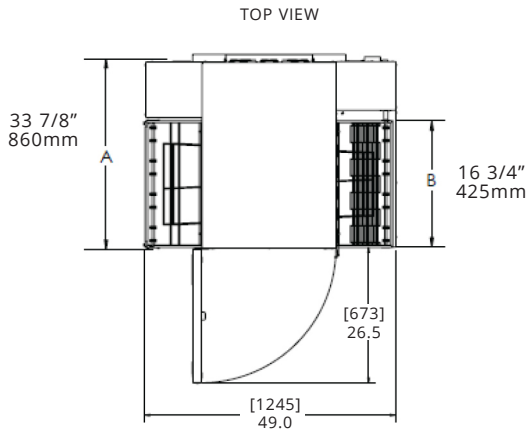

FRONT VIEW, SINGLE ON COUNTERTOP WITH LEGS

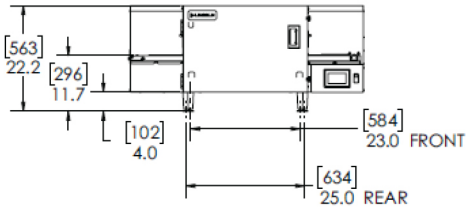

FRONT VIEW, DOUBLE-STACK ON COUNTERTOP WITH LEGS

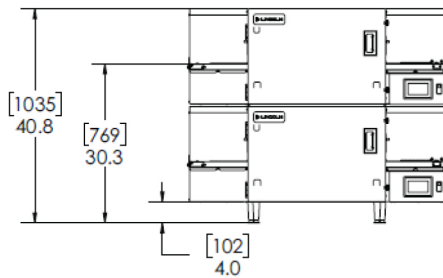

FRONT VIEW, TRIPLE STACK ON CASTERS

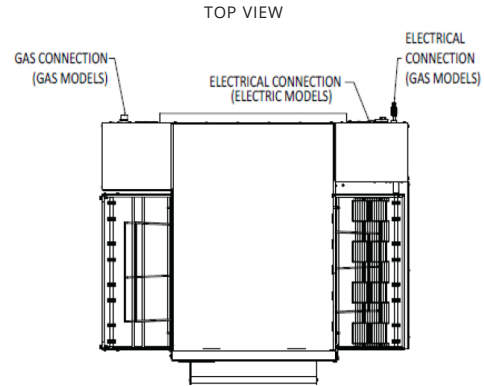
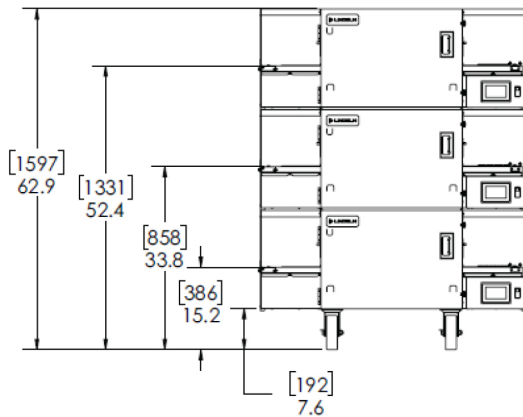

SIDE VIEW, SINGLE ON COUNTERTOP WITH LEGS

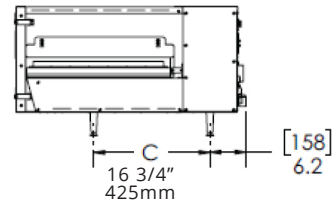

FRONT VIEW, SINGLE ON LEGS WITH CASTERS

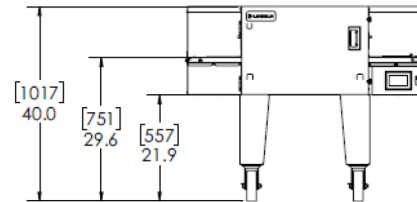

FRONT VIEW, DOUBLE-STACKED ON LEGS WITH CASTERS

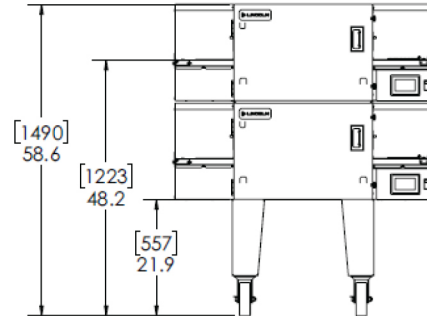

FRONT VIEW TRIPLE STACK (EXPORT)

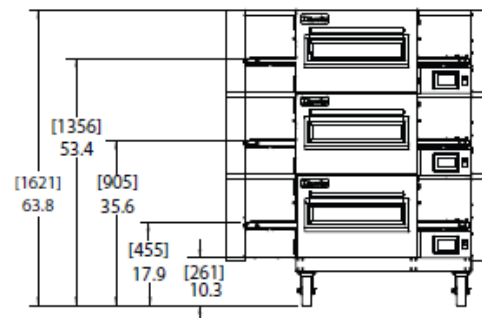

General Information

MODEL	DIMENSIONS						Shipping Weight	Shipping Cubic Feet
	A - Model Depth		B - Conveyor Width		C - Leg Spacing, side			
	inch	mm	inch	mm	inch	mm		
All 1624 Models	33-7/8	860	16-3/4	425	16-9/16	421	330 lbs (150KGS)	34.6 CU FT (1 CU M)

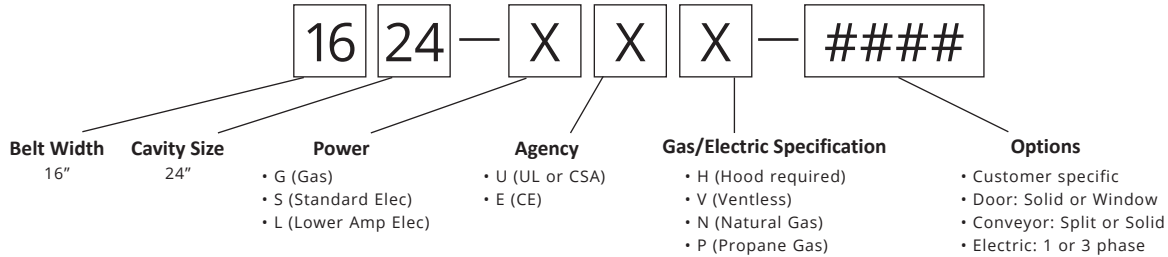

Utility Specifications

Electric Ovens

Region	Phase	Configuration	Voltage (VAC)	Current (A)	Power (kW)	Frequency (Hz)	Recommended Electrical Specification	Circuit Breaker Rating (A)	Optional Plug Type
US/Canada	3	1624-SU	208 - 240	38.5 - 44.3	13.9 - 18.5	60	4 Wire, 3 Poles + G	50/60	NEMA 15-60P Ⓢ
	3	1624-LU	208 - 240	26 - 29.9	9.4 - 12.5	60	4 Wire, 3 Poles + G	35/40	NEMA 15-60P Ⓢ
US	1	1624-LU	208 - 240	37 - 42.5	7.7 - 10.2	60	3 Wire, 2 Poles + G	50	NEMA 6-50P Ⓢ
Canada	1	1624-LU	208 - 240	37 - 42.5	7.7 - 10.2	60	3 Wire, 2 Poles + G	50/60	

Export Electric Ovens

Region	Phase	Configuration	Voltage (VAC) 3PH: L-L 1PH: L-N	Current (A)	Power (kW)	Frequency (Hz)	Recommended Electrical Specification
Export	1	1624-LEH*	220 - 240	39.3 - 42.7	8.7 - 10.2	50/60	3 Wires (1 Pole + N + G)
Export	1	1624-LEV*	220 - 240	39.3 - 42.7	8.7 - 10.2	50/60	3 Wires (1 Pole + N + G)
Export	3	1624-LEH*	380 - 415	17.3 - 18.6	10.3 - 12.2	50/60	5 Wires (3 Poles + N + G)
Export	3	1624-LEV*	380 - 415	17.3 - 18.6	10.3 - 12.2	50/60	5 Wires (3 Poles + N + G)
Export	3	1624-SEH*	380 - 415	24.6 - 26.6	15.0 - 18.0	50/60	5 Wires (3 Poles + N + G)
Export	3	1624-SEV*	380 - 415	24.6 - 26.6	15.0 - 18.0	50/60	5 Wires (3 Poles + N + G)

Gas Ovens

Region	Configuration	Fuel	Max Input Rate	Burner Pressure	Voltage (VAC)	Current (A)	Phase	Frequency (Hz)	Electrical Input Configuration
US/Canada	1624-GUP*	LP Gas	60,000 BTU/hr	10" W.C.	120	9	1	60	3 Wire, L + N + G
	1624-GUN*	Natural Gas	60,000 BTU/hr	4" W.C.	120	9	1	60	3 Wire, L + N + G

** NOTE: For proper operation, the gas valve requires a nominal inlet pressure of 7 inches of W.C. for natural gas. A minimum inlet pressure of 1.0 inch of W.C. column above the manifold setting (NAT. manifold 4" W.C.) must be maintained with no pressure drop from the no load to full load condition. The maximum inlet pressure must be maintained at or below 1/2 PSIG (14.5 inches W.C.)

*Gas supply pressures are dependent on local gas type and on all applicable local codes. Agency approved flexible connection to each oven must be minimum 3/8" (19 mm) NPT and length must not exceed six (6) feet (1829 mm).

All ovens require separate electrical service and breaker.

*Oven requires use of a dedicated neutral.

Permitted Stacking Configurations

Oven Model	Under Exhaust Hood?	Supporting Surface is:	Single Oven	Double Stacked	Triple Stacked
1624-#UV	No	Floor	√	√	√
1624-#UV	Yes	Floor	√	√	√
1624-#UH	Yes	Floor	√	√	√
1624-GU*	Yes	Floor	√	√	√
1624-#UV	No	Counter	√	√	
1624-#UH	Yes	Counter	√	√	
1624-GU*	Yes	Counter	√		

- S [High Power] or L [Low Power]

* - P [LP Gas] or N [Natural Gas]

Ventilation Requirements

Ventilation is required for Gas and Electric [Non-Ventless] models. Local codes prevail. These are the “authority having jurisdiction” as stated by the National Fire Protection Association, Inc., in NFPA 96-1994. Estimates of CFM requirements can vary from 750 to 2500 CFM [1274 and 4248 m³/hour] exhaust.

In all cases the ambient temperature around the oven must not exceed 95°F (35°C) when the oven is operating. **This information is shown as a guideline for ventilating the Lincoln 1624 Aperion® Impinger Conveyor oven.**

Recommended Minimum Clearances

GAS OVENS	Minimum Clearances to combustible construction		Minimum Clearances to non-combustible construction		ELECTRIC OVENS	Minimum Clearances to combustible and non-combustible construction	
	Sides	Back	Sides	Back		Configuration	Sides
Configuration	Sides	Back	Sides	Back	Configuration	Sides	Back
Triple Stacked	10"	0"*	6"	0"*	Triple Stacked	6"	0"*
Double Stacked	10"	3"	6"	3"	Double Stacked	6"	3"
Single	4"	3"	4"	3"	Single Stacked	4"	3"

* Required for optimal cooling

* Note: When triple stacked the ovens must be fitted with heat shields at the rear, which contact the back wall.

Warranty

All new Aperion ovens come with a two (2) year parts and labor factory warranty from the date of install and approved start-up. Ovens must be installed within 18 months from date of manufacture.