



Equipment for the Foodservice Industry

value + quality + service

Cube Ice Machine



IM-350

Features

Features:

- Convenient, built-in scoop holder
- Easily removable baffle, no tools required for cleaning
- Light weight
- Corrosion resistant
- Ice scoop included
- Makes full cube sized ice

Warranty:

- One year parts and labour
- Specifications subject to change without notice



IM-350

Specifications

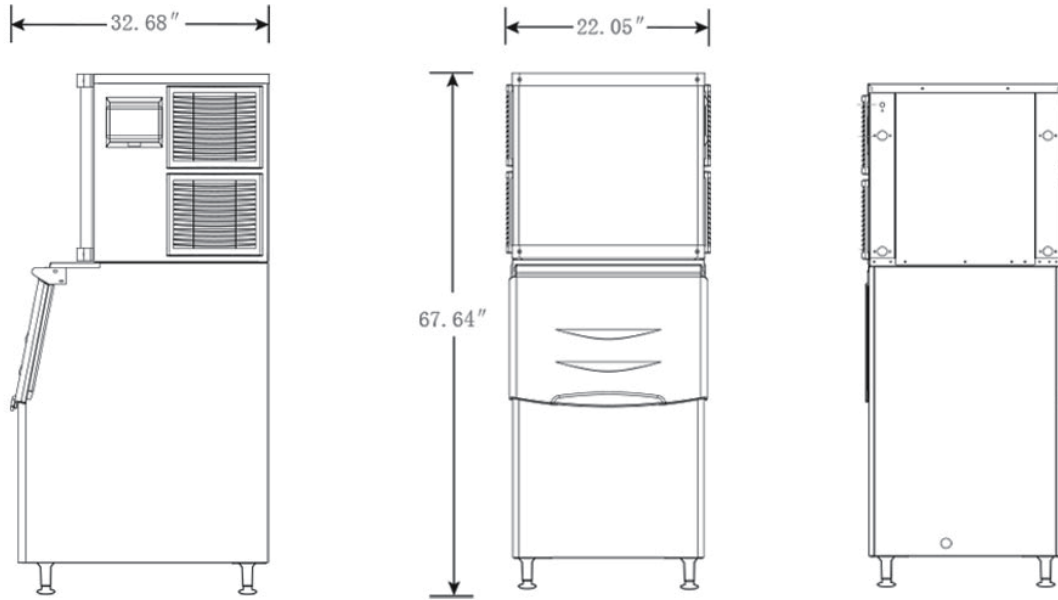

Model	Refrigerant	Dimension (mm) (inch)			Condenser Unit	Voltage (V/Hz)	Power (W)	Bin Capacity (KG) (LBS)	Output LB/24hr (KG) (LBS)	Net Weight (KG) (LBS)
		L	D	H						
IM-350	R290	560	830	1718	Air	110/60	790	125	160	93
		22	32.7	67.6				275	350	205