



Equipment for the Foodservice Industry

value + quality + service

Undercounter Freezer

FUDR1-27VC-R



FUDR1-27VC-R Features

Features:

- Exterior & interior stainless steel construction
- Environmentally friendly R290 refrigerant
- Heavy duty Embraco compressor
- Self-closing and stay open door
- Efficient refrigeration system
- Recessed door handle
- Removable gasket that is easy to clean and replace
- Casters for easy movement
- Pre-installed shelves

Warranty:

- Two year parts and labour; Five years on compressor. For full warranty details visit <https://www.efifoodequip.com/warranty-info.php>



FUDR1-27VC-R Specifications

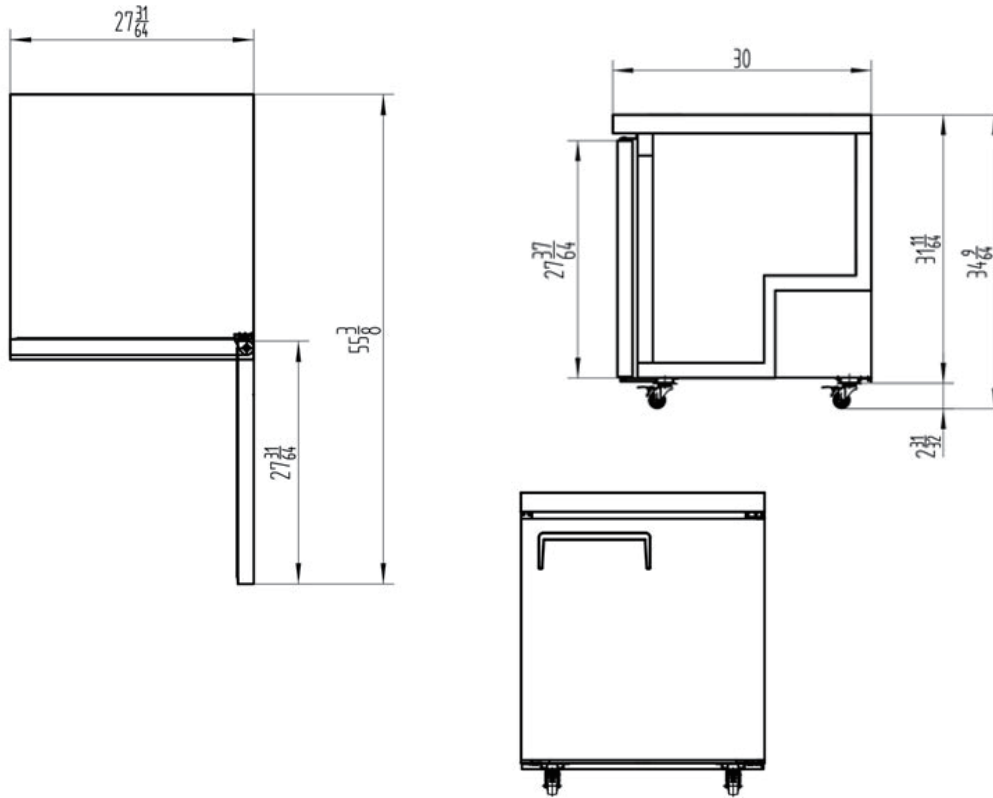

Model	Refrigerant	Doors	Shelves	Dimension (mm) (inch)			HP	Voltage	Amps	Capacity (L) (Cu Ft.)	Net Weight (KG) (LBS)	Temperature Range
				L	D	H						
FUDR1-27VC-R	R290	1	1	698	762	866	1/5	115/60	1.8	202	66	-8 ~ -1°F
				27.5	30.0	34.1				7.2	145	-22 ~ -18°C

Equipped with one NEMA 5-15P plug 

Shipping Information

Crate Dimensions (mm) (inch)			Net Weight (KG) (LBS)	Gross Weight (KG) (LBS)
L	D	H		
752	831	980	66	81
29.6	32.7	38.6	146	179

Specifications subject to change without notice.