



Equipment for the Foodservice Industry

value + quality + service

Salad/Sandwich Prep Tables

CSDR1-27VC-L



CSDR1-27VC-L Features

Features:

- Front breathing, side mount compressor
- Exterior & interior stainless steel construction
- Environmentally friendly R290 refrigerant
- Heavy duty Embraco compressor
- Self-closing and stay open door
- Efficient refrigeration system
- Recessed door handle
- Standard safety door lock
- Magnetic door gaskets
- Casters for easy movement
- Pre-installed shelves

Warranty:

- Two year parts and labour; Five years on compressor. *For full warranty details visit <https://www.efifoodequip.com/warranty-info.php>*



CSDR1-27VC-L Specifications

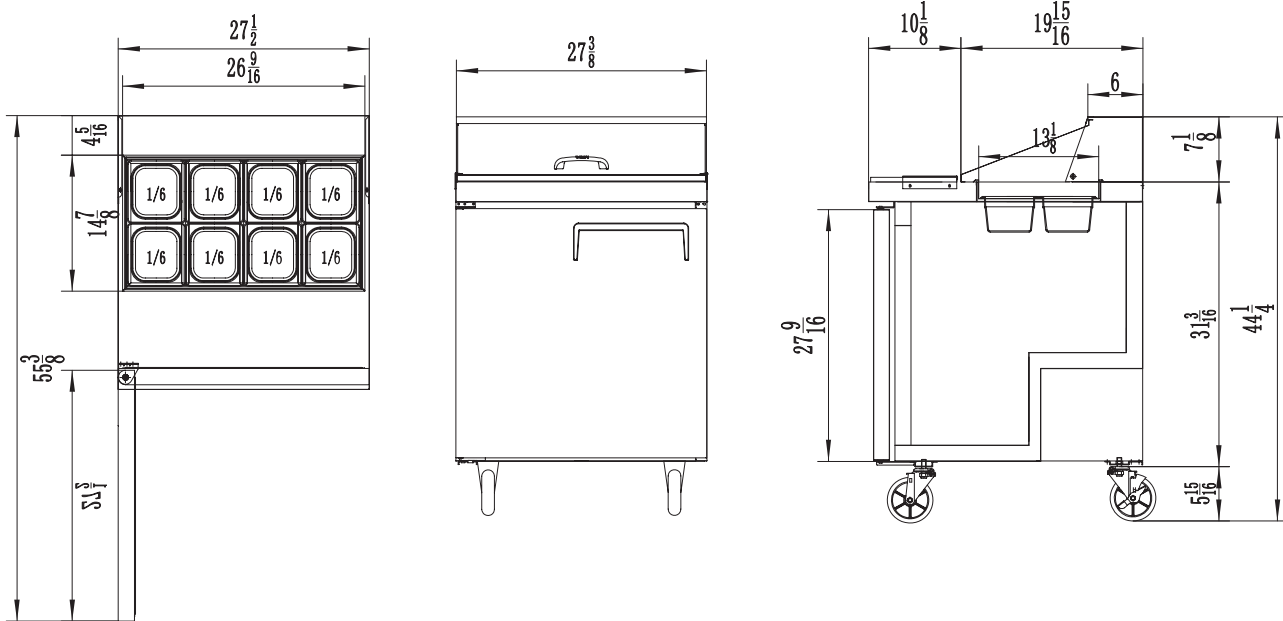

Model	Refrigrant	Doors	Shelves	Dimension (mm) (inch)			HP	Voltage	Amps	Capacity (L) (Cu Ft.)	Net Weight (KG) (LBS)	Temperature Range
				L	D	H						
CSDR1-27VC-L	R290	1	1	698	762	1109	1/6	115/60	2.3	202	72	1 ~ 8°C
				27.5	30.0	43.7				7.2	158	33 ~ 45°F

Equipped with one NEMA 5-15P plug 

Shipping Information

Crate Dimensions (mm) (inch)			Net Weight (KG) (LBS)	Gross Weight (KG) (LBS)
L	D	H		
752	831	1186	72	89
29.6	32.7	46.7	159	196

Specifications subject to change without notice.



EFI Sales Ltd.
Vancouver Office
26895 Gloucester Way
Langley, BC V4W 3Y3

EFI Sales Ltd.
Toronto Office
474 Attwell Drive
Toronto, ON M9W 5C3

Distribution Facilities:
Langley, BC
Toronto, ON

(604) 607-8850 Vancouver
(416) 798-7776 Toronto
(888) 565-9920 Toll Free
(604) 607-8820 Fax
info@efifoodequip.com