



Equipment for the Foodservice Industry

value + quality + service

## Bottom Mount Reach-in Glass Door Refrigeration

C2-54GDSVC



### C2-54GDSVC

### Features

Features:

- Bottom mount compressor units
- Environmentally friendly R290 refrigerant
- Led lighting interior display system
- Dixell digital temperature control system
- Heavy duty Embraco compressor
- Self-closing and stay open door
- Efficient refrigeration system
- Recessed door handle
- Standard safety door lock
- Magnetic door gaskets
- Pre-installed castors
- Pre-installed shelves

Warranty:

- Two year parts and labour; Five years on compressor. *For full warranty details visit <https://www.efifoodequip.com/warranty-info.php>*



**C2-54GDSVC Specifications**

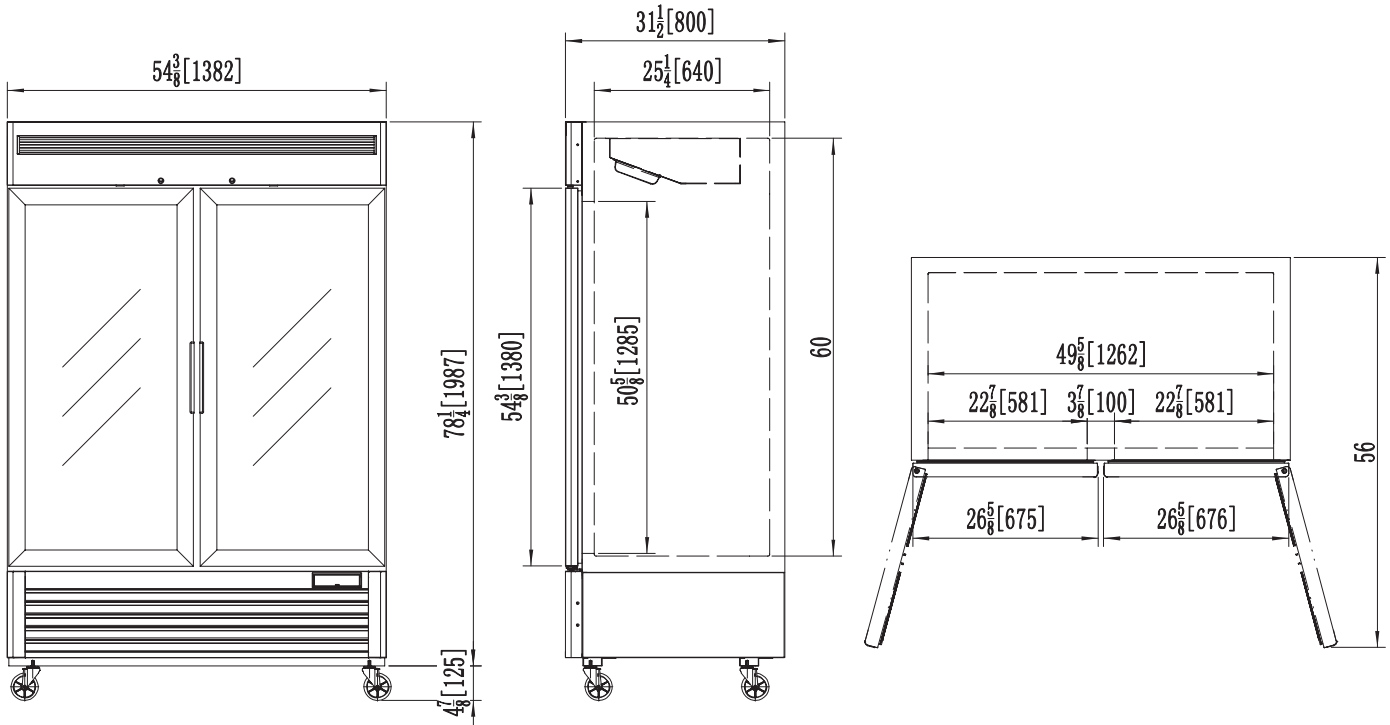

Model	Refrigerant	Doors	Shelves	Dimension (mm) (inch)			HP	Voltage	Amps	Capacity (L) (Cu Ft.)	Net Weight (KG) (LBS)	Temperature Range
				L	D	H						
C2-54GDSVC	R290	2	8	1382	800	2135	1/3	115/60	3.2	1268	220	1 ~ 8°C
				54.4	31.5	84.1						

Equipped with one NEMA 5-15P plug 

**Shipping Information**

Crate Dimensions (mm) (inch)			Net Weight (KG) (LBS)	Gross Weight (KG) (LBS)
L	D	H		
1435	862	2154	220	2455
56.5	33.9	84.8	485	540

Specifications subject to change without notice.