

WAREFORCE®

WAREFORCE® CG-115

Project _____
Item _____
Quantity _____
CSI Section 11400 _____
Approval _____
Date _____

WAREFORCE® CG-115

Models

WAREFORCE CG-115



Standard Features

- Cleans 1,200 glasses an hour
- 12" clearance allows cleaning of taller stemware, glasses and mugs
- Composite carousel conveyor prevents chipping and damage to glasses, mugs and stemware
- Low-water protectors for pump and wash heating element
- Quick-removal side panel allows tool-free access to vacuum breakers for ease of service
- Simplified, front access to all controls and chemical settings
- Efficient 1/10 hp wash pump
- Conveniently located conveyor drive motor
- Single-switch, auto-fill operation
- Convenient, expanded chemical storage inside machine
- Built-in chemical pumps and priming switches
- Wash/rinse temperature gauges
- Durable stainless steel construction
- Adjustable rinse control allows hot or cold water final rinses for flexible sanitizing methods
- Adjustable bullet feet
- Unit fits compactly underbar
- Removable wash/rinse arms with removable end caps on (both lower and upper) wash/rinse arms combine for ease in cleaning
- Double-wall cabinet for quiet operation and less heat loss

Accessories/Options

- Scrap tray
- Scale Prevention System (SPS)
- Replacement Cartridge for SPS

Specifications

12" (305 mm) wash clearance

Quick-removal side panel allows tool-free access to vacuum breakers

Efficient 1/10 hp wash motor

Low-water protection for wash pump and wash tank heating element

Automatic conveyor system with composite carousel to prevent damage to glasses, mugs and stemware

Cleans 1,200 glasses per hour

Gravity drain

Removable end caps on (both lower and upper) wash and rinse arms for cleaning

Built-in chemical pumps and priming switches

Solid-state and electromechanical components

Clockwise rotation is standard

Durable stainless steel construction



Intertek

WAREFORCE®

WAREFORCE® CG-115

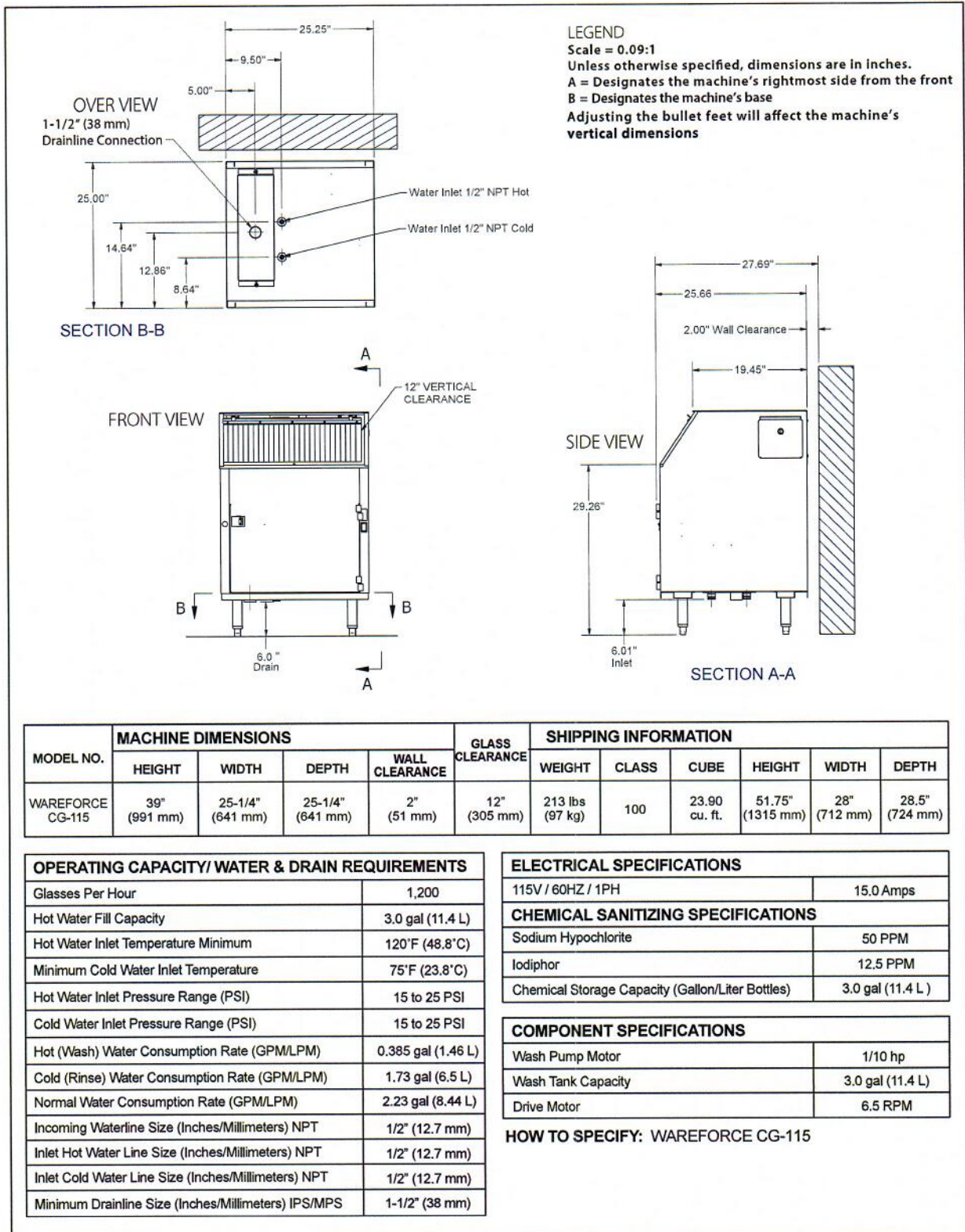

WAREFORCE®

Shipping Address: 6209 North U.S. Highway 25E, Gray, KY 40734

Mailing Address: P.O. Box 1060, Barbourville, KY 40306

Telephone: 888-800-5672 • Fax: 606-523-1799

Email: info@jacksonwws.com

07610-004-28-05 [03/30/17]

We reserve the right to change specifications in this bulletin without incurring any obligation for equipment previously or subsequently sold.